

Service Bulletin

Keep you up to date with the latest news from Frank Mohn Services AS

Handling of High Viscous Molasses

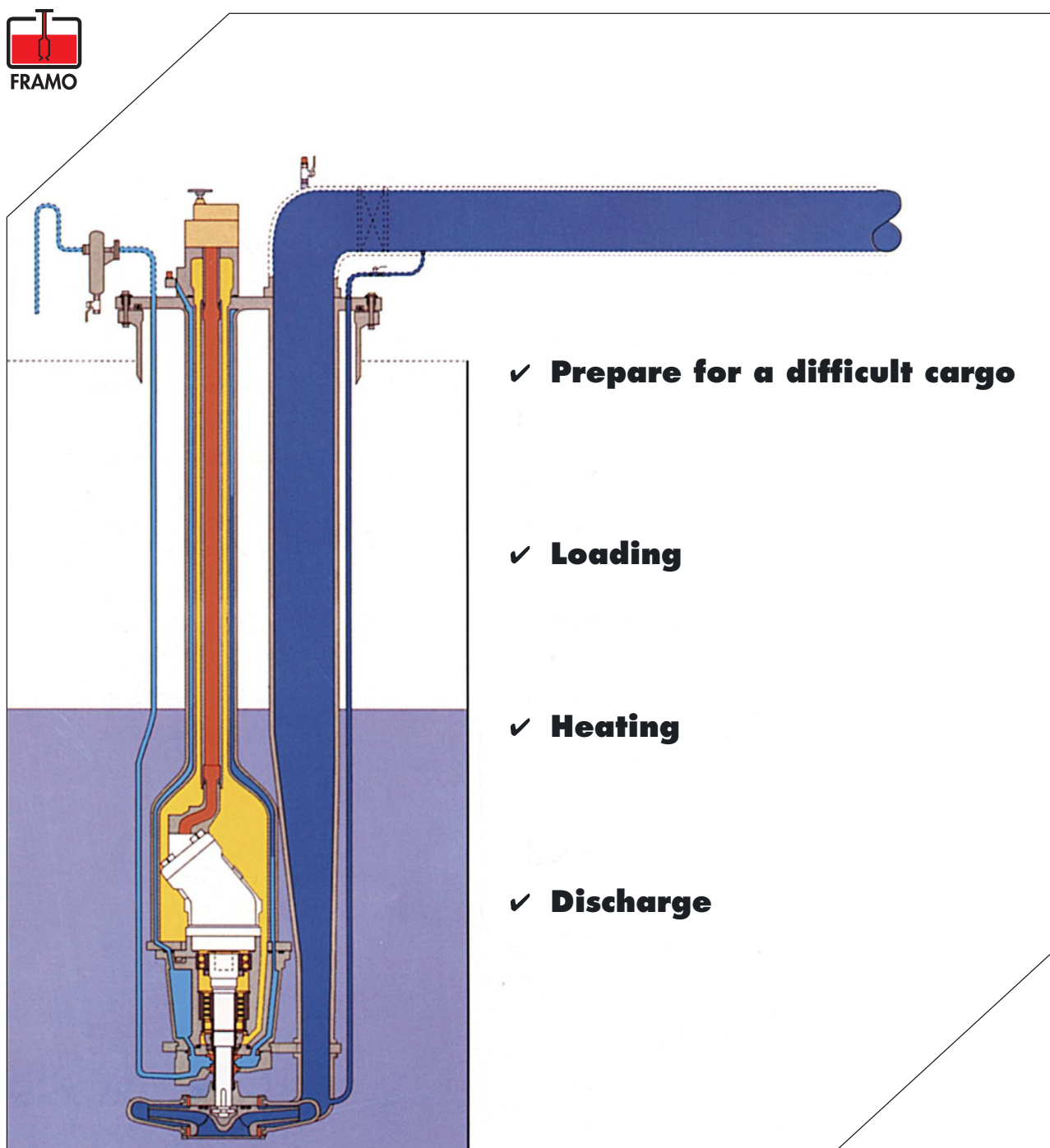

Dear Customer

Handling of extreme molasses is complicated and several problems have arisen because there has not been taken sufficient precautions for this difficult cargo.

Molasses is a non newtonian fluid and the pumpability does not only depend on viscosity, but where the molasses comes from, the storage time, the fermentation process in the molasses, brix value etc.

It is of great importance that the loading of the molasses is done in a manner avoiding foam building up.

Further the cargo heating during the voyage has to be carefully balanced with a low temperature on heating medium in order to avoid crystallisation of molasses on and near the heating coils. At the same time the heating has to be sufficient for ensuring a high temperature and even distribution throughout the entire cargo tank, enabling the molasses to be as pumpable as possible.

Since the molasses is very sensitive to heat, and overheating leads to crystallisation, heating should preferably be done by heating coils and hot water as heating medium, if steam is utilized as heating medium steam pressure has to be reduced. For vessels equipped with heat exchangers on deck, make sure you have sufficient circulation of cargo through the heater. Because of all these variables it is impossible to calculate an expected discharge rate on beforehand.

To minimize the problem with this cargo we therefore recommend you to take proper precautions, and in addition to your own experience we would highlight:

- Load the cargo through dropline at the bottom of the tank.
- Keep the temperature of the molasses close to the discharge temperature during the entire voyage.
- Make sure you have waterfilling/flushing of cargo pump cofferdam the whole period you have molasses in the tank to avoid burning of pump's cargo seals.
- Make sure that the actual molasses is pumpable with the ship's pumps.
If in doubt, prepare with special portable pumps and booster pump to increase the discharge capacity.
- Adding of limited quantity of water will improve the pumpability, make necessary option in the charter party.

If you need any further assistance, please contact one of Framo Service Stations world-wide.



Frank Mohn Services AS

Head office: Frank Mohn AS, P.O. Box 98 Slåtthaug, 5851 Bergen, Norway, Phone: + 47 55 99 90 00, Telefax: + 47 55 99 93 80

Frank Mohn Flatøy AS, Flatøy, 5918 Frekhaug, Norway, Phone: + 47 55 99 94 00, Telefax: + 47 55 99 95 81

Frank Mohn Fusa AS, P.O. Box 10, 5641 Fusa, Norway, Phone: + 47 55 99 96 00, Telefax: + 47 55 99 97 80

Frank Mohn Services AS, P.O. Box 44 Slåtthaug, 5851 Bergen, Norway, Phone: + 47 55 99 92 00, Telefax: + 47 55 99 93 82

Framo Engineering AS, P.O. Box 174 Sandsli, 5862 Bergen, Norway, Phone: + 47 55 92 88 00, Telefax: + 47 55 92 89 00

Frank Mohn Nederland BV, Edisonweg 18, P.O. Box 305, 3200 AH Spijkenisse, The Netherlands, Phone: + 31 181 619311, Telefax: + 31 181 611193

Frank Mohn Houston Inc, 1802 West D Street, La Porte, Texas 77571-4601, USA, Phone: + 1 281 471 7920, Telefax: + 1 281 842 5450

Frank Mohn Singapore Pte Ltd, 17 Tuas View Circuit, Singapore 637575, Phone: + 65 6210 2400, Telefax: + 65 6210 2401

Frank Mohn AS Sweden Office, Askims Industriväg 1A, 43634 Askim, Sweden, Phone: + 46 31 682085, Telefax: + 46 31 681048

Frank Mohn Nippon K.K., City-haz Chojamachi Building 6-3, Chojamachi 2-chome, Naka-ku, Yokohama 231-0033, Japan, Phone: + 81 45 253 7155, Telefax: + 81 45 253 7188

Frank Mohn Korea Office, Rm. 309, Yachting Center Bldg., 1393, Woo-1 Dong, Haeundai-Ku, Pusan, Korea, Phone: + 82 51 743 6942, Telefax: + 82 51 743 6944

Frank Mohn China Ltd, Unit 1008 Pine City, 8 Dong An Road, Shanghai 200032, China, Phone: +86 21 6443 8845, Telefax: +86 21 6443 8846

Frank Mohn do Brasil Ltda, Av. Presidente Vargas, 463 - 19° Andar, Rio de Janeiro - CEP 20071-003, Brazil, Phone: + 55 21 2507 7898, Telefax: + 55 21 2507 7888